

Massage Chair

RK2005

User 's Manual

*Make your life healthy
and beautiful every day!*

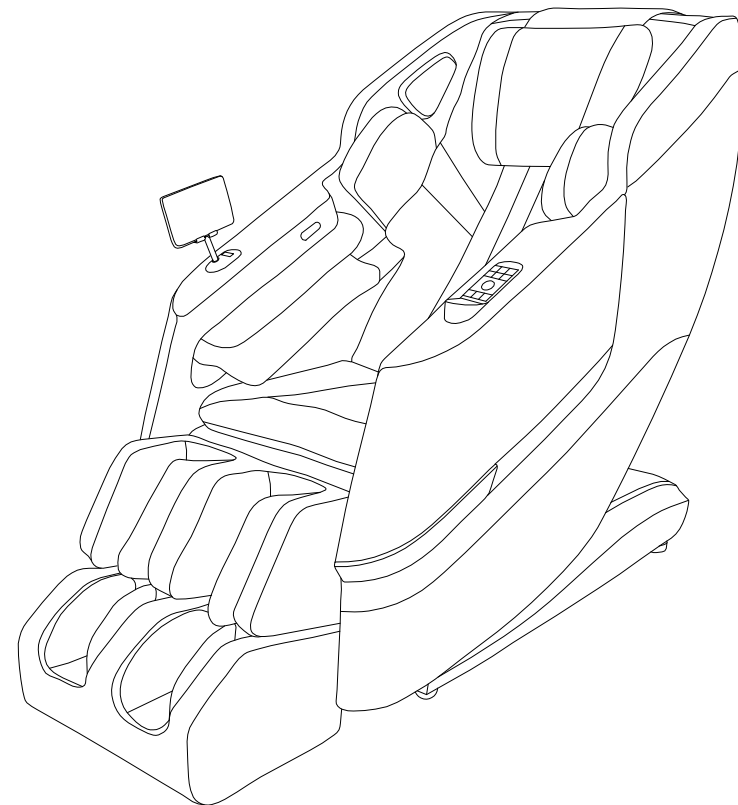

Please read SAFETY INSTRUCTIONS carefully before using the chair.

- ✦ 1.Thank you for choosing this Massage Chair RK2005.
- 2.Please read this manual carefully before using the massage chair.
- 3.Please keep this manual in a safe place for further reference.
- 4.Please pay attention to SAFETY INSTRUCTIONS.

✦ Note: We reserve the right for design modification.It is subject to change without notice.The pictures in this manual are only for reference. Please refer to the actual product.

Content

Preparation	Safety instructions -----	1
	External structure parts -----	5
	Internal structure parts -----	6
	Mechanical components diagram -----	7
	Mechanical components list -----	8
Installation	Installation -----	9
Massage Operation	The adjustment before massage -----	13
	The method of application for the built-in remote -----	15
	Manual control -----	17
	Voice control use method -----	19
	Operation instruction &function illustration -----	20
	After massage -----	21
Maintenance	Clean and maintenance -----	22
Others	Malfunction guide -----	23
	Technical data -----	24

Please keep this manual in a safe place for future reference.

- ★ Please read this manual carefully to make sure the installation and operation of the massage chair is correct.
- ★ “Safety Instructions” is provided in both Warning and Caution for important safety information.

Both Warning and Caution are important safety caution, please pay more attention.

	Warning	This sign indicates warning of causing possible death or hurt to body.
	Caution	This sign indicates caution of causing possible hurt or damage to things.

Symbol meaning

	This sign indicates forbidden behavior.		This sign indicates self disassembly is forbidden.
	This sign indicates must follow instruction to operate.		This sign indicates correct operation of cable.

- ★ The following should be kept for any further references.



Warning

	<ul style="list-style-type: none"> ● People with osteoporosis, vertebral fractures, and acute painful diseases such as sprains or muscle strains. ● Heart disease patients (including those who have pacemakers or are using other medical electronics). ● Cancer patients. ● People with perceptual disorders due to high levels of peripheral circulatory disturbances such as diabetes. ● People with abnormal spine or crooked spine. ● People with Protruded intervertebral Disc. ● Pregnant women and those who have just completed childbirth, as well as people with poor health. ● People with trauma, such as thrombosis, acute varices, and various skin inflammations. ● People who have been identified as having lost their ability to discern temperature. ● People with high fever (acute inflammation: such as burnout, chills, blood pressure changes, physical weakness). ● Elderly people over 80. ● Persons with impaired consciousness, mentally handicapped persons, or those who are incapable of operating the unit are prohibited from using this unit. ● People who can not take care of themselves, infants, and drunkards. ● Do not use this unit when it is wet or when you are wet. ● It must be taken care of, or not used by people who are not sensitive to heat or people who are allergic to heat. ● Do not fall asleep in this unit. <p>People with above symptoms should not use massage chair, or use it under doctor's advice. User's discretion is advised if use the chair.</p>	<p>Not suitable users.</p> <p>Risk of causing accident or body discomfort.</p>
--	--	--



Warning

	<ul style="list-style-type: none"> ● Before sitting, please confirm that there are no foreign matter inclusions between the various parts of the machine. ● When using the backrest or footrest up and down, make sure that there are no people or objects around (behind, under, or in front of the chair). ● In the event of a physical abnormality or abnormality in use, stop using it immediately and ask a doctor. ● Massage around the head should pay attention to the movement of the massage rollers, the head should not do too much or too strong massage. ● Pay special attention when you massage the area around your neck. ● Avoid excessive neck massage. ● Do not massage the abdomen or knees with this machine. ● If you want to leave your seat during the massage, you must stop the massage chair before you leave the seat. ● Do not use it with other instruments. ● Do not allow children or pets to play on or around the unit (especially in use); nor can they sit or stand on backrests ,armrests or legrest. ● When people are inconvenient for action or lack of communication skills, they must have strict and continuous care. ● Before moving the unit, the backrest and legrest must be angled back to their original position. 	Accident/injury
	<ul style="list-style-type: none"> ● When assembling, turn off the switch and unplug it after the chair returns. ● Insert the plug of the chair into correct and suitable power socket. Make sure the plug is completely inserted into the socket to reduce short circuit or fire risk. ● Unplug the power when not in use, stop all massage functions and turn off on/off key before unplugging. 	Fire and electric shock
	<ul style="list-style-type: none"> ● Massage cushions of the chair are not allowed to fold for storage. ● The machine is forbidden for no-load running for a long time. ● An appliance should never be left unattended when plugged in. 	Accident
	<ul style="list-style-type: none"> ● Power cord, plug, socket can't be used in broken or loose contact condition. ● Don't use other electric power except rated voltage in case of fire, electric shock or any breakdown. ● Any broken, re-process, knotted, twisted power cord or pressed under heavy cargo is not allowed to use. ● Never operate this appliance if it has a damaged cord or plug, if it is not working. ● Keep the power line away from stove or other heating products. 	Fire and electric shock
	<ul style="list-style-type: none"> ● If the chair works dysfunctional, or is broken, splashed with water or falls into water, please have it repaired by professional repairman or send the chair to assigned service agent. Self-modification, disassembly or maintenance is forbidden. ● If power cord or plug is damaged, please don't replace it yourself, please contact us or appointed dealer for replacement. ● To avoid electric shock or body hurt, please don't open or disassemble any part of the chair, there is not any attached part of the chair for maintenance by customers. ● Check leather or cloth material on the back and other areas is broken or not. If broken, even though it is small, please stop using the chair, unplug the power and have it repaired 	Disassembly and maintenance

**Caution**

	<ul style="list-style-type: none"> This product is intended for use by individuals weighing below 120 kilograms. 	When used by overweight individuals, the product may generate significant noise during operation, and the fabric may wear out more quickly.*	
	<ul style="list-style-type: none"> Please operate the chair in a flat or level place. 	To avoid sudden falling.	
	<ul style="list-style-type: none"> The maximum suggested operating time is 20mins. 5mins for each position beginning with the slight- step massage. Along continuous massage in the same position may cause uncomfortable feeling. 	Too long time massage is bad for your body.	
	<ul style="list-style-type: none"> Before sitting on the chair to avoid injury please inspect everything to confirm that the massage heads are in the correct position. 	To avoid accidental injury.	
	<ul style="list-style-type: none"> The tablet controller should be placed on the tablet stand in time, and do not place it randomly to avoid the tablet controller being squeezed or damaged by falling. 		
	<ul style="list-style-type: none"> Please make sure that the power switch is at the "OFF" position before inserting the plug into the socket. 		
	<ul style="list-style-type: none"> Turn off all controls before removing plug from outlet. 		
	<ul style="list-style-type: none"> Make sure the plug completely insert into the socket. 	To avoid the accident when turn on the power.	
	<ul style="list-style-type: none"> Checking whether any damage on wire, make sure no water or rubbish on wire. 	To reduce short circuits and any fire hazard.	
	<ul style="list-style-type: none"> Installing earth wire in correct way. The plug must be inserted into socket with earth connect, the earth connect couldn't be bend or cut off. 	To avoid electric shock in any leakage or breakdown.	
	<ul style="list-style-type: none"> Don't press with hands or step on the massage heads with feet. Don't put hands between the working massage heads. Don't put hands or feet in the gap of mechanical parts. Don't drop or embed anything into the slot of massage chair. Don't stand or sit or put anything on the backrest, armrest or leg-rest. Don't move the chair during operation. Don't stand on the chair during operation. Don't pull out the plug or turn off the power during operation. Don't put your hands or head between leg-rest or beneath. Don't use the massage chair while wearing hair ornaments. Don't put hard things in pocket when take buttocks and huckle massage. Don't sit or press on the backrest when the chair is in reclining position. Don't use at bare skin or wore thin clothes, thin clothes may can achieve better massage effect, But it also may cause irritation to the skin or cryogenic burns. Do not use massager in close proximity to loose clothing or jewelry. Keep long hair away from massager while in use. 	To avoid accidents or injury	
		<ul style="list-style-type: none"> Keep the chair away from heat, wet, sharp things and corrosive, inflammable, explosive environment. To use electric blanket or other heating products on the chair is forbidden. 	To avoid fade, discolor on upholstery or hardened, deteriorated on PU.
		<ul style="list-style-type: none"> Keep the chair away from stove or other heating products. Don't put the chair directly under the sun or other high temperature places. Don't put in the space of dust serious or corrosive gas environment, Don't put the chair in a small space places or use in the bad air circulation places. 	
		<ul style="list-style-type: none"> Don't use the chair outdoor. 	

**Caution**

	<ul style="list-style-type: none"> Keep Dry-Don't use or store the chair in the wet environment like nearing the swimming pool, or bathroom. Keep the chair and remote control dry all the time. Do not use it when user's body is wet. 	To avoid leakage or electric shock.
	<ul style="list-style-type: none"> Make sure to install the earth wire in correct way(Incorrect install way may cause electric shock. If you don't know how to install, please find a professional electrician) Don't use plug adapter (If the enclosed plug doesn't match with socket, please don't change the plug by yourself and find a professional electrician to install a matched socket.) 	To avoid electric shock.
	<ul style="list-style-type: none"> Unplug the power before cleaning the chair. Unplug the power after using the chair. 	To avoid electric shock or fire hazard.
	<ul style="list-style-type: none"> Unplug the power when any damage on the power. 	
	<ul style="list-style-type: none"> Hold the plug to unplug the power but not try to pull the wire to unplug the power. 	To avoid accidents
	<ul style="list-style-type: none"> Please turn off the power switch and unplug the power after massage. 	To avoid damage or accidents when power on again.

Usage environment	Environment temperature : 0°C~35°C Relative humidity : 20%~80%
Storage environment	Environment temperature : -5°C~35°C Relative humidity : 20%~80%

Grounding instruction

- ✦ ※The chair is equipped with a cord having a grounding conductor. The plug must be plugged into an appropriate socket that is properly installed and matched with the plug.

Replace fuse

- ✦ ※When the fuse is burned out, please turn off the switch and unplug the power. Opening the lid covered the fuse which is located in the switch box. Using a same size fuse to replace the old one, then cover the lid. Or you can find an electrician to replace the fuse.

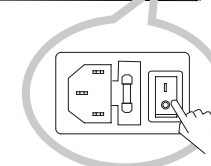
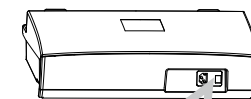
**Earth wire is not allowed to be in these places**

Gas pipe: probably cause explosion or fire.
 Phone wire and lightning rod: probably cause electric shock and fire when thundering.
 Water pipe: earth wire is useless where there are plastics

External structure

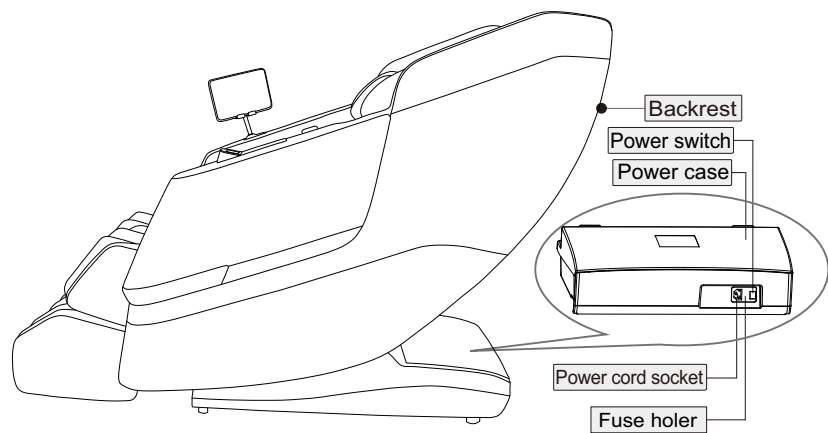
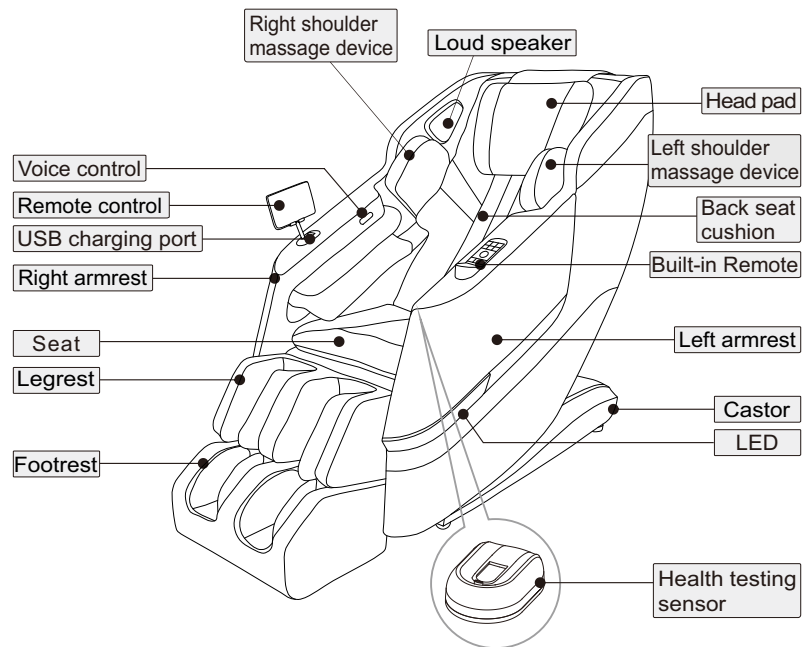

Preparation

Internal structure

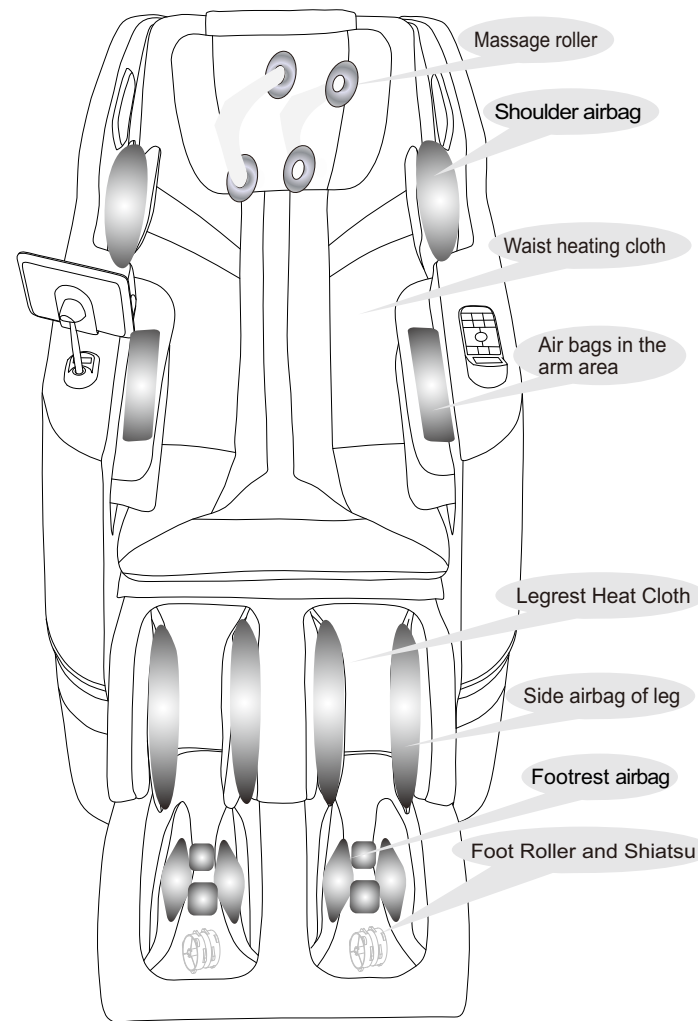

Preparation

Explosion Diagram

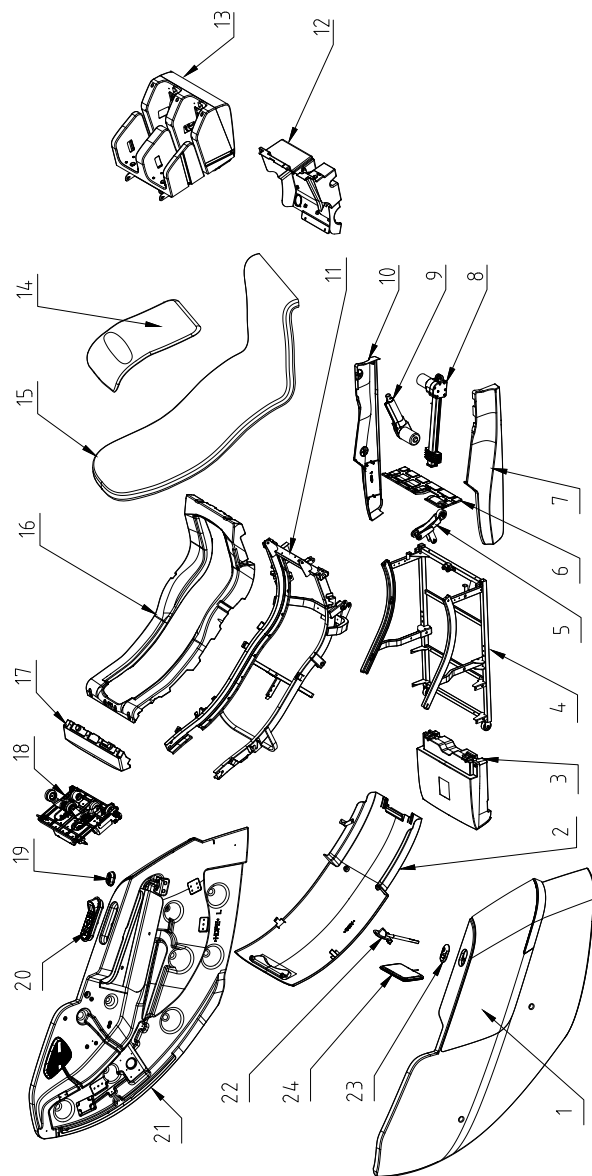

Preparation

Mechanical components list

NO.	Name	Q' ty	NO.	Name	Q' ty
1	Right armrest assembly	1	22	Tablet bracket assembly	1
2	Backrest cover	1	23	Fixed base upper cover	1
3	Power box assembly	1	24	Tablet controller	1
4	Seat frame welding assembly	1			
5	Leg link (electrophoresis)	1			
6	Front fender	1			
7	Right side fender	1			
8	Pushing actuator	1			
9	Electric actuator	1			
10	Left fender	1			
11	Back frame welding assembly	1			
12	Backrest lower cover	1			
13	Legrest assembly	1			
14	Pillow	1			
15	Back seat cushion	1			
16	Lower backrest plastic	1			
17	Upper backrest plastic	1			
18	Massage machine	1			
19	Healthtesting assembly	1			
20	Built-in Remote	1			
21	Left armrest assembly	1			

Preparation

Installation (1)

Step 1 Take out massage chair and accessories from the carton box, and reset the footrest.

- ① Take out the accessories box and other parts, and lift out the massage chair body by two or more people.
- ② Turn the footrest from the upper seat to front of the seat.
- ③ Paste the snap fastener of footrest connecting leather on front of the seat.
- ④ Check to make sure that all accessories are complete (please check one by one against the packing list).

Massage chair main body

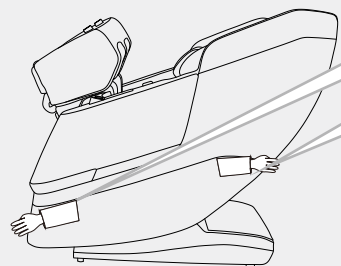

①

Two people each hold the front position of the lower end of the armrest with one hand; Hold the backrest cover handle with the other hand and slowly lift it out.

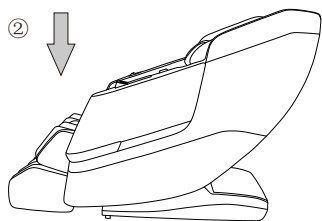

②

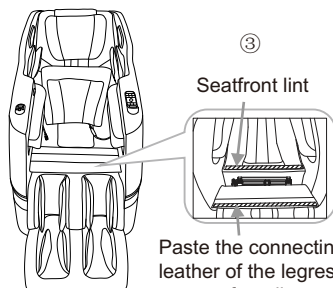

③

Seatfront lint

Paste the connecting leather of the legrest on seat front lint

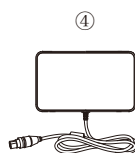

④

Tablet controller



Tablet control bracket

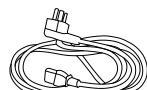

Electric power cable

Installation (2)

● Check environment

- Make sure the recline space.

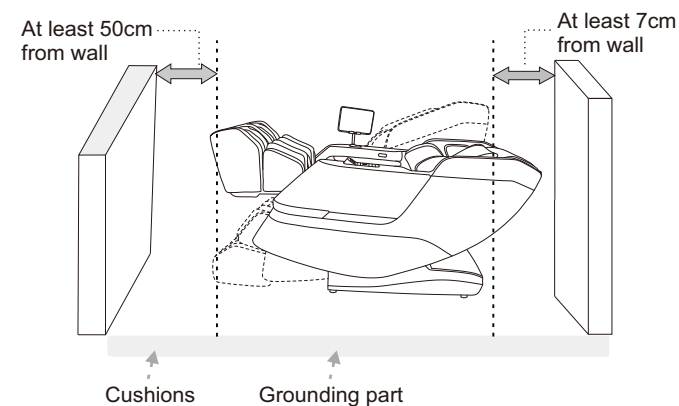

Because the chair is heavy, it may ruin your floor in long time placement. Please put a blanket or other soft things to protect your floor.

Installation (3)

Step 2. Assemble controller and controller holder

① Insert the controller holder into the socket on the right armrest, according to the shape of the controller holder and socket hole, until the bottom screw of the bracket snaps into place. ② Align the concave position of the hand control plug with the convex position of the hand control wire socket on the right side of the seat, connect them together, and then tighten the nut. ③ Put the tablet controller on the holder.

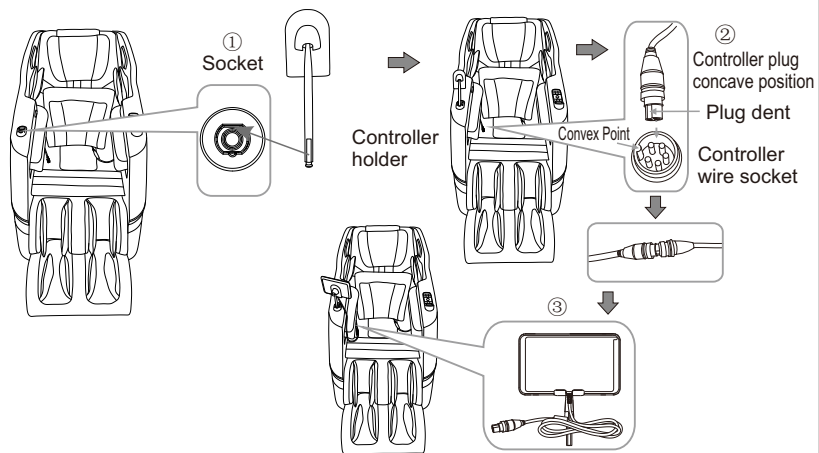
**Step 3. Connect heater wire and back-seat cushion**

Connect the heater wire of waist and seat, connect the back cushion and back with zipper.

★ **Kind suggestion**

Sitting on the chair, try to keep the bottom of pillow and ear in the same line, then connect it with back in this position. It will make body detection more accurate and provide better massage.

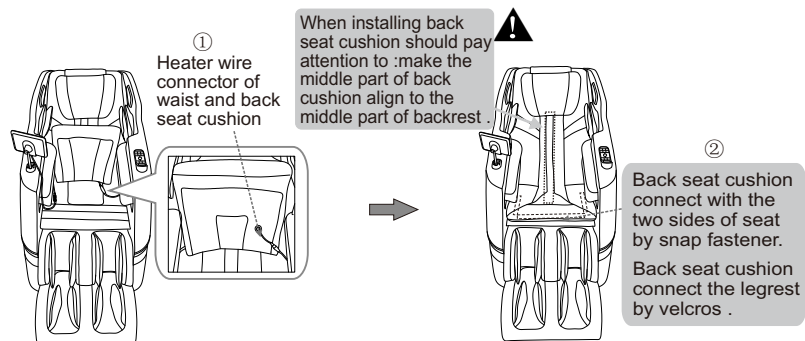

Installation (4)

Step 4. After assembling.

- 1 Plug the cable line in the hole a on the power box as shown in the right picture.
- 2 Insert the plug of cable line into the socket.
- 3 Turn on the switch behind the power box. (Switch on/off "O/I", press I down to turn it on.)
- 4 Use the hand controller to choose massage functions, enjoy the relax and comfortable massage by our products.

Make sure the switch is off before you insert the plug of cable line into the socket.

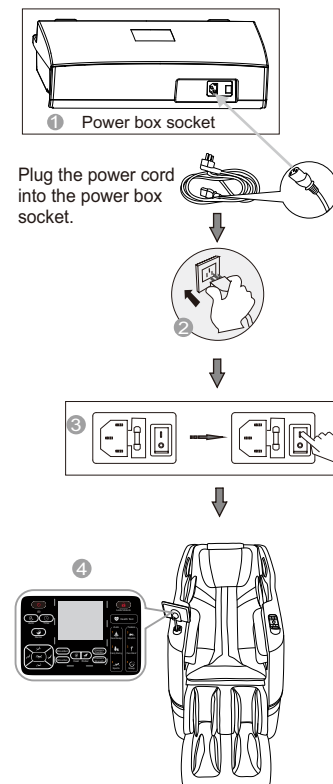

Environment

 Caution

Don't use the chair in wet places like near swimming pool, bath room to avoid leakage or electric shock.



Don't use under sunlight or near stove or other heating place to avoid upholstery deteriorated.



Please use chair in flat place to avoid chair falling or noise or other unexpected trouble.

● Check places in front

Check the areas when back and leg extending, make sure no people, pets or other things around.

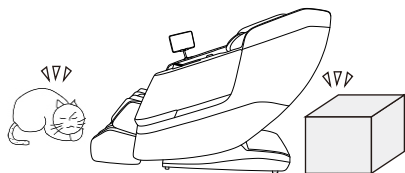

● Check power cable, plug

- (1) Clean the dust on plug on time. (using dry cloth).
- (2) No damage, re-do, bend, stretch, tie or press with heavy thing (especially can't be pressed by the chair) on power cable.

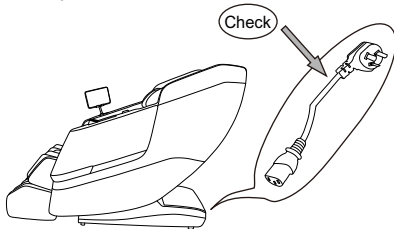

Check environment

● Space size for using the chair

- At least 7cm for the back-rest from the wall.

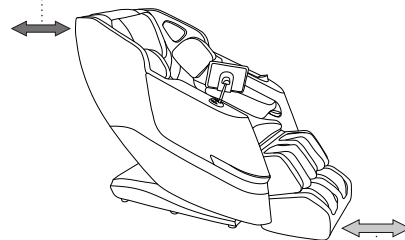

- At least 50cm in front of the leg.

● Check surroundings

When the backrest or legrest reclines or extends, please pay attention to:

- (1) Check any person or things in every direction.
- (2) Check the space size.

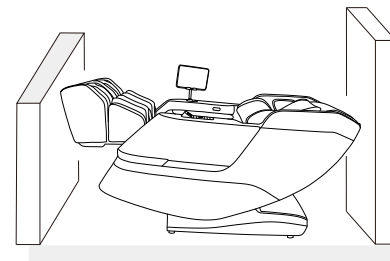
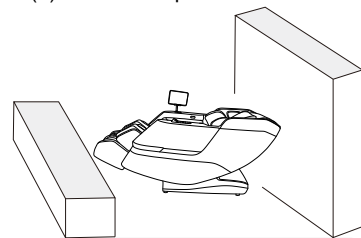

How to move massage chair

 Caution

- ✦ Don't move chair when it's working in case of accidents or damage

How to move

- ✦ Bind the cables and put them in the seat to avoid damage when moving.
- ✦ If you plump the chair, it may damage the inner parts of the chair.
- ✦ Don't use the castor if the floor is wooden or other easy damaged material. It will need 2 or more persons to lift the chair.
- ✦ Make sure the power is off and the plug doesn't touch the floor (It's better to let the chair in standing status to avoid the back crashing the floor)



Normally

- 1 Press down the head part to make the gravity fall on the back castors. Then push the chair to desired destination steadily and set it down slowly.

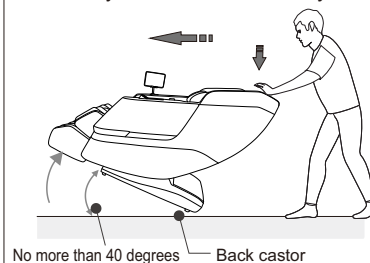

 Please hold the footrest to move the chair as shown in the picture in case any scratches on the leatherette

During massage chair backrest lie down process, can't move the armrest.

Adjustment before massage

● Before adjustment

- ✦ Make sure the massage machine rollers stop in the seat of backrest, then sit on the chair slowly

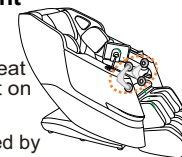

- ✦ To avoid injure caused by wrong position of the massage head.

✦ Shoulder height detection

When detecting the height of shoulder, If the massage machine rollers can not find the position of shoulder, it will set the middle back is shoulder by default.

Right position: Your back cling to the chair back, the head clings to the pillow.



● Kind suggestion

- ✦ When you feel the neck massage is not strong enough, please lift the pillow and shoulder cushion, then massage again.

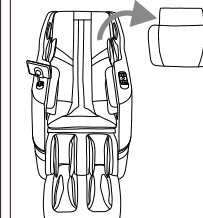

- ✦ Because the chair is heavy, it may ruin your floor in long time placement. Please put a blanket or other soft things to protect your floor.

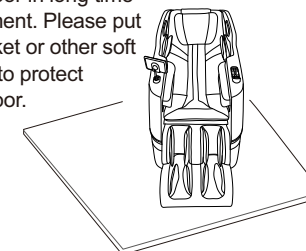

Built-in Remote Instructions

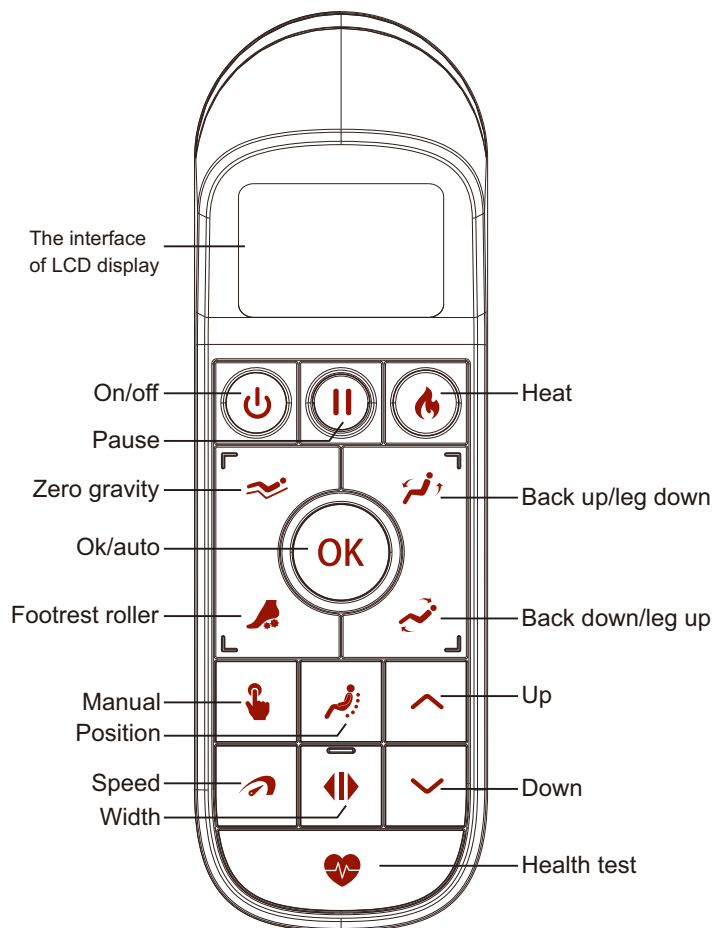

1. In standby mode, press this key, the chair enters the power-on state. At this time select any Auto massage programs or manual massage program, the massage machine will start to detect the shoulder height and start the massage. Press this key again to turn off the massage chair.



2. In ON status, press this key to pause the chair, press the key again to resume the massage. In pause status, all the keys can not operate except the stop key and ON/OFF key.



3. In ON status, press this key, to turn on & turn off the heat.



4. In the power-on state, press this key to adjust the chair position to Zero gravity. Then press this key again to reset the chair to the initial working state.



5. In ON status, press this key to turn on & turn off the foot rollers.



6. In ON status, hold this key, the backrest goes up and the footrest goes down. Release this button the backrest and footrest stop moving.



7. In ON status, hold this key, the backrest goes down and the footrest goes up. Release this key the backrest and footrest stop moving.



8. In ON status, every time press this key to change an automatic program and there is corresponding display on the screen. There are 22 automatic programs for choice. Quick Demo, Chinese Massage, Relax, Leg & Foot, Full Body SPA, Vitality, Spinal Relaxation, Men Mode, Women Mode, Elderly Mode, Neck Shoulder, Glutes, Sports Recovery, Cervical Traction, Lumbar Traction, Full Body Traction, Neck Massage, Waist Massage, Back Massage, Morning, Midday, Night.

After the health testing function is completed, the test result will be displayed. Press this button to enter the recommended program interface. In the recommended program interface, you can press the up and down keys to select program, and press this key again to confirm the selected program is working.



9. In ON status, every time press this key to change a massage method. There are 9 massage methods for choice. Positive Kneading, Tap, Kneading & Tap, Rolling, Knock, Reverse Kneading, Palm Kneading, Finger kneading, Rhythmic Clapping. There is corresponding display on the screen.



10. In ON status and manual mode, press this key to change the massage position such as full body, partial, fixed point.



11. In ON status and manual mode, press this key to choose the massage speed from level 1~level 5.



12. In ON status and manual mode, press this key to choose the massage width such as wide middle narrow.



13. In ON status and the manual fixed point mode, long press this key the massage machine goes up. Release this key and the massage machine stop moving. In the shoulder height detection mode, press this key to adjust the shoulder position goes up, release this key to stop it. In the healthy detection mode press this key to choose the program wanted.



14. In ON status and the manual mode, long press this key the massage machine goes down. Release this key and the massage machine stop moving. In the shoulder height detection mode, press this key to adjust the shoulder position goes up, release this key to stop it. In the healthy detection mode press this key to choose the program wanted.



15. In the ON state, when there are no other functions running, press this button to enter the health testing mode, and the LCD screen displays the health test progress. Please adjust to the most comfortable sitting position and place your index finger directly above the health testing sensor (gently place, do not press hard) to maintain a relaxed mood, adjust your breathing evenly, and keep still. Start testing, and upon health testing data, the flashing frequency of the button backlight will change based on the data. The LCD screen displays a progress bar and "Under testing...". When the test data is abnormal, it will pop up "Please adjust the finger posture and force". After adjusting, the progress bar will restart. When the progress bar reaches 100%, complete the testing and pop up the results interface. The results include blood oxygen, heart rate, fatigue level. In the health test results interface, press the OK key to confirm the results and enter the recommended program interface. Press the up and down keys to select a program and press the OK key to run the program. In health testing mode, pressing this key will exit the health testing mode.

Tips: Health testing is only for reference and cannot be used for diagnosis or treatment of any disease. If you are concerned about any abnormalities in your body, please consult professional medical personnel for professional examination.

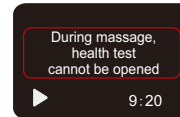

Health testing function is not available while running the massage program.

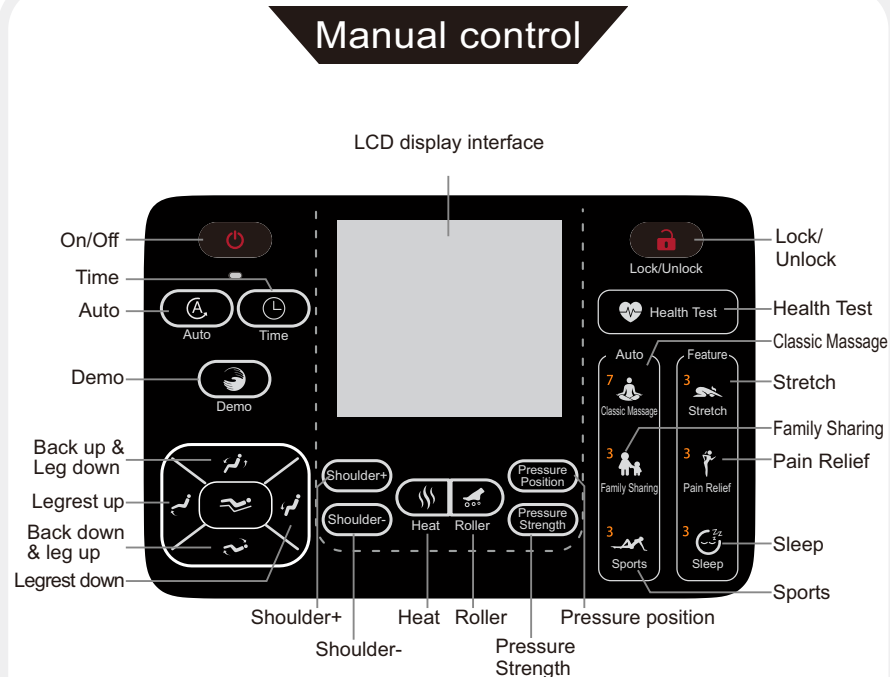

1. In standby mode, press ON/OFF key, the massage chair go into the ON status; In ON status, press the ON/OFF key, the massage chair will turn off and return to original status.



Lock/Unlock

2. In ON status, if there is no any operation in 1 minute or press the Lock, all buttons will enter the lock mode, now only ON/OFF, pause and unlock button can be used; Press the unlock button in the Screen to cancel the lock mode.



Auto

3. In ON status, press this key to change the automatic programs, there are 21 auto programs except Demo.



Time

4. In ON status, Press Time button, to adjust the chair massage time, 10mins, 20mins and 30mins for choice.



Demo

5. In ON status, press the button to enter the “Demo” massage program.



6. In ON status, press this key to start the health testing mode, the result of testing will display at the built-in remote.



7. In ON status, press and hold this button, the backrest goes up and leg goes down, release this button, the backrest and leg stop running.



8. In ON status, Press and hold this button, the backrest goes down and leg goes up, release this button, the backrest and leg stop running.



9. In ON status, Press and hold this button, the leg will rise up, release this button, the leg will stop running and lock this position.



10. In ON status, Press and hold this button, the leg will go down. release this button, the leg will stop running and lock this position.



11. In ON status, press this button to adjust the chair posture to Zero gravity, then press the button again to set the chair to the initial working state.



Shoulder+

12. In ON status, when the shoulder height detecting completed and shoulder height can be adjusted. Press this key to adjust shoulder height rise, Release this key to stop shoulder height adjustment.



Shoulder-

13. In ON status, when the shoulder height detecting completed and shoulder height can be adjusted. Press this key can adjust shoulder height down, Release this key to stop shoulder height adjustment.



Heat

14. In ON status, press this key to turn on and turn off the heating.



Roller

15. In ON status, press this key to turn on and turn off the foot roller.



Pressure Position

16. In ON status, press this key to turn on the manual air pressing, which can switch between whole body, upper body and lower body and stop.



Pressure Strength

17. In ON status and air pressure massage, press this key to adjust the air pressure intensity. 5 levels can be adjusted.



18. Auto program: "Classic massage" corresponds to 1-7; 'Family exclusive' corresponds to 8-10; 'Sports and leisure' corresponds to 11-13; Traction stretching corresponds to 14-16; 'Pain relief' corresponds to 17-19; Sleep relaxation corresponds to 20-22. Quick Demo, there are a total of 22 automatic programs that can be switched by pressing the corresponding buttons.

Voice control use method

The use of smart voice control (with voice control function)

In the standby status, press the ON/OFF button to turn on the chair, the voice recognition enters the waiting status.



- When using the voice recognition function, it is necessary to say the wake-up word "Hello, Kiri" before the system can recognize the subsequent voice control words. After the Voice mode is activated, if no voice control words is given within 8 seconds, the voice mode system shut down automatically.
- After the massage chair recognizing the voice control words, there will be corresponding speaker voice feedback, indicating that the voice command recognition is successful. If there is no voice feedback from the speaker, the voice command recognition fails or the current status does not support this function.

Voice control words :

Awakening words : Hello Kiri

1. classic massage 2. Family exclusive 3. Sports&leisure 4. Stretch 5. Pain relief
6. Sleep relaxation 7. Health testing 8. Zero gravity

- If no response, please try again louder after 2 seconds.

Voice control command description:

Classic massage	Activate the automatic program in classic massage, and cycle through 7 automatic programs: Quick Demo, Chinese massage, Relax, Leg and Foot, Full Body SPA, Vitality, and Spinal Relaxation.
Family exclusive	Activate the automatic program family exclusive, and cycle through 3 automatic programs: Men mode, Women mode, and Elderly mode.
Sports&leisure	Start the automatic program in sports and leisure, and cycle through 3 automatic programs: white-collar, shopping experts, and fitness experts.
Traction stretching	Activate the automatic program in stretch, and cycle through the 3 automatic programs of Cervical traction, Lumbar traction, and Full body traction.
Pain relief	Activate the automatic program for Pain relief, and cycle through the 3 automatic programs of Neck massage, Waist massage, and Back massage.
Sleep relaxation	Activate the automatic program for sleep relaxation, and cycle through 3 automatic programs: Morning, Middy, and Night.
Health testing	Health testing function is not available while running the massage program.
Zero gravity	Start zero gravity function.

ON/OFF

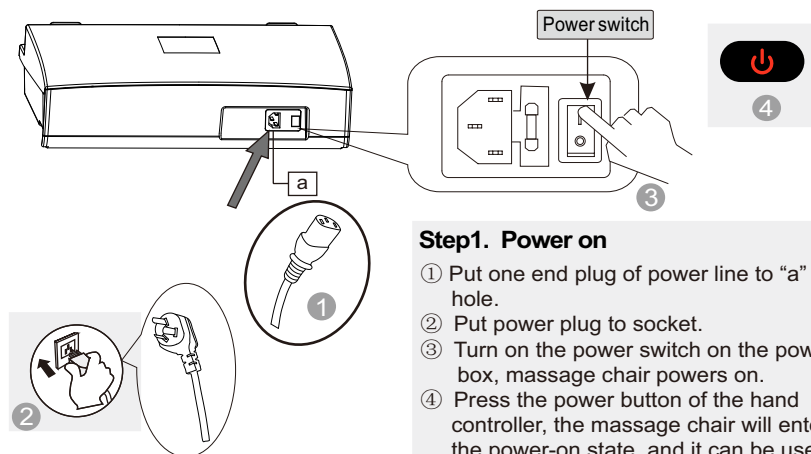

Step1. Power on

- ① Put one end plug of power line to "a" hole.
- ② Put power plug to socket.
- ③ Turn on the power switch on the power box, massage chair powers on.
- ④ Press the power button of the hand controller, the massage chair will enter the power-on state, and it can be used normally.

Step2. Massage

- ① Operate according to controller operation instructions. As for the massage method's details, please refer to remote control's Usage page.
- ② When the massage ends, massage machine will return to the default position, meanwhile "Shutting down" will be displayed on the controller.



Remote control

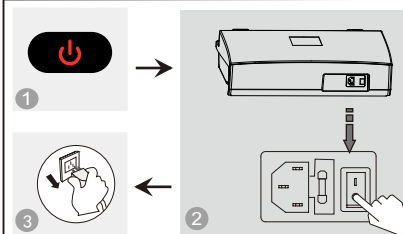

Step3. Turn off the power

- ① When the chair is On, press On/Off button to turn off the massage chair and it will restore automatically.
- ② Turn off the power switch on the bottom of the back of chair after the rollers reach storage position.
- ③ Unplug the power plug from the socket.



Warning

1. Before using, pull up the pillow, back cushion etc. to check if the PU material is broken, if there is damage, please stop using, unplug the chair, and ask for repairment.
2. Only plug to proper socket.



Attention

1. Before sitting down, make sure there is no things pinched between armrest, legrest, backrest and seat of the chair.
2. Make sure the chair is in reset state before using.
3. Do not stand on it when using the massage chair.
4. The upper cover of the power box is provided with a safety anti-pinch device. When there is squeezing or a heavy object between the power box and the back cover of the backrest, the backrest will stop reclining.

Restoration of massage chair

- 1 Make sure there is no people or pet or anything within the range of backrest and legrest.

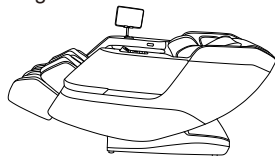

- 2 Make backrest and legrest restore to the normal position by controller. (or press ON/Off key to make backrest and legrest restore to the normal position)

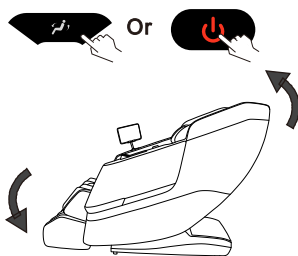

- 3 After the chair restore in place, put the hand controller back on the controller bracket of the right armrest.

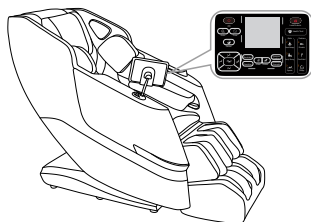

- 5 Switch off the power.

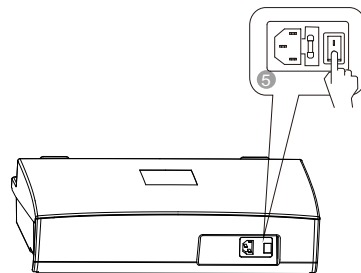

- 6 Unplug the electricity from the socket. (Attention: hold the right plug position)

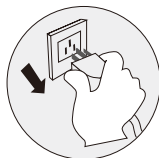

- 7 Clean the chair if necessary.



Attention!

- After using, press ON/OFF to end all the massage method and wait for restoration. Make sure to cut the electricity to avoid any unexpected hurt to children or pets.
- After using, turn off the power, unplug the electricity. Avoid moisture, dirt and aging of insulation in case of causing damage.



1. Please make sure there is no people, no pets or any stuff around the backrest to avoid unexpected hurt or property loss.
2. When adjusting the backrest, be careful of the gap between the backrest and armrest.
3. When the legrest is moving, please do not stand on or leave from the seat, do not stop the legrest from moving in case of causing damage to the chair.
4. Please refer to control instruction for more details.

Synthetic leather

● General cleaning

Clean with tidy, soft and dry cloth slightly.



(Chemical or medical cleaning products are forbidden)

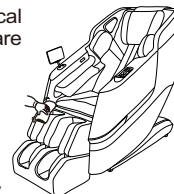

● If leather is dirty

- 1 Dip soft cloth into 3-5% neutral detergent solution, squeeze it then clean the stain on the surface gently.
- 2 Wash cloth, squeeze it and wipe with detergent.



- 3 Clean it softly with dry cloth.
- 4 Allow to dry (air blower is prohibited)

Cloth material

- 1 Dip cloth into weak neutral detergent, squeeze it and clean the material surface.

- (Diluent, gas, alcohol are prohibited)

Brush the dirty parts with weak neutral detergent. (avoid excessive brushing)

- 2 Excessive cleaning may cause damage to cloth material.
- 3 Wipe with water-dipped but squeezed cloth.
- 4 Allow to dry.

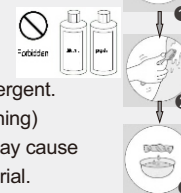

Plastic parts

- 1 Dip cloth into neutral detergent, squeeze it and clean.
- 2 Wipe with water-dipped but squeezed cloth.
- 3 Allow to dry.



Clean the controller

- 1 Wipe with soft cloth after squeezing.
- 2 Allow to dry. Propellant, diluent or alcohol are prohibited.



Remote control



About cleaning

- Before cleaning, unplug the electricity, don't touch plug with wet hands.
- Make sure hands are dry when plugging to the socket.
- If failed to follow the mentioned instruction, user may get electric shock or burned.

FAQ and Troubleshooting

Trouble	Possible reason	Troubleshooting
The massage chair can't work after power is on.	Check if the control is on or not.	Open control switch
	Not choose massage function	Choose massage function
	Check whether the plug and socket in poor contact.	Make sure plug and socket are connected.
	Wire or plug has damaged.	Please ask manufacturer or appointed or authorized maintenance man for checking and replacement.
	The fuse burned out.	Replace fuse of same specification.
	Something wrong with inner circuit	Please ask appointed or authorized maintenance man for checking and repairing.
There is beep sound inside the massager while working.	It is sound of air pump, motor and mechanical parts.	Normal sound, no need to pay attention to it.
Different height of the left roller and right roller.	Massage rollers work on shifts.	Normal, no need to pay attention to it.
Sound suddenly becomes much louder while working.	Check if it is due to long time working.	Turn off the power to have the massager rest for over half an hour before next turn working.
	Inner parts fretted away due to long time work. It's normal	Please ask appointed or authorized maintenance man for checking and repairing.
Massage function suddenly stops while working.	Suddenly power-down	Connect the electricity power again
	Setting time is up.	Turn off the power to have the massager rest for over half an hour before next turn working.
Neither the backrest nor the legrest can be lay down.	Check if there are any obstacles; the chair overloads; for the sake of safety, sometimes the massage machine may automatically stop working. There is heavy things on power box.	Remove the obstacles; turn off the power to have the massager rest for over half an hour before next turn working.
The chair can't return to its original position.	Excessive operation; setting time is up.	Please ask manufacturer or appointed or authorized maintenance man for checking and replacement.
Electric wire or plug give out heat	It may work overload	Turn off the power to have the massager rest for over half an hour before next round working.
	Other abnormal case	Stop using, and ask appointed maintenance man for help.



Note: If the troubles are not caused by above reasons, please turn off the power switch and cut off the power, then contact the manufacturer or service agent to repair your chair.

Others

Technical data

Name	Massage Chair	Power	150W
Model	RK2005	NW/GW	84.4/102.4kg
Input voltage	<input type="checkbox"/> 120V ~ 60Hz <input type="checkbox"/> 220V ~ 50/60Hz <input type="checkbox"/> 240V ~ 50Hz	Packing size	1315×790×1185mm (L×W×H)
Safety design	Class I		

Others